



**BALTIMORE
AIRCOIL COMPANY**



PFI Closed Circuit Cooling Towers

RIGGING AND INSTALLATION INSTRUCTIONS





About rigging and installation

The BAC equipment should be rigged and installed as outlined in this bulletin.

These procedures should be thoroughly reviewed prior to the rigging and operation to acquaint all personnel with the procedures to be followed and to assure that all necessary equipment will be available at the job site. Be sure to have a copy of the unit certified drawing available for reference. If you do not have a copy of this drawing or if you need additional information about this unit, contact the local BAC representative. His name and phone number can be found on the www.BaltimoreAircoil.com. The model type and serial number of your equipment are indicated on the unit nameplate.

Recommended maintenance and monitoring programme

Checks and adjustments	Start-Up	Weekly	Monthly	Quarterly	Every 6 months	Annually	Shutdown
Cold water basin and basin strainers	X			X			
Operating level and make-up	X		X				
Blow down	X		X				
Sump heater package	X				X		
Belt tension	X		X				
Drive alignment	X					X	
Drive system	X				X		
Locking collar	X						
Rotation of fan(s) and pump (s)	X						
Motor voltage and current	X			X			
Unusual noise and/or vibration	X		X				

Inspections and monitoring	Start-Up	Weekly	Monthly	Quarterly	Every 6 months	Annually	Shutdown
General condition	X		X				
Heat transfer section and drift eliminators	X				X		
Combined inlet shields	X			X			
Water distribution	X				X		
Fan shaft & Axial fan	X			X			
Fan motor	X			X			
Spray water pump	X			X			
Electric water level control package (option)	X				X		
Level or alarm switches				X			
TAB test (dip slides)	X	X					
Circulating water quality	X		X				
System overview	X					X	
Record keeping	as per event						

Lubrication	Start-Up	Weekly	Monthly	Quarterly	Every 6 months	Annually	Shutdown
Fan shaft bearings	X			X			X
Motor bearings*	X				X		
Adjustable motor base	X				X		X
Hinges & access doors bolts						X	

* only for motors with grease fittings with typical frame size > 200L (>30 kW)

Cleaning procedures	Start-Up	Weekly	Monthly	Quarterly	Every 6 months	Annually	Shutdown
Mechanical cleaning	X					X	X
Disinfection**	(X)					(X)	(X)
Drain basin and pump							X

** depends on applied code of practice

Notes

1. Water treatment and auxiliary equipment integrated in the cooling system may require additions to the table above. Contact suppliers for recommended actions and their required frequency.
2. Recommended service intervals are for typical installations. Different environmental conditions may dictate more frequent servicing.
3. When operating in ambient temperatures below freezing, the unit should be inspected more frequently (see Cold weather operations in the appropriate Operating and Maintenance Instructions).
4. For units with belt drive, tension on new belts must be readjusted after the first 24 hours of operation and monthly thereafter.



Table of contents

RIGGING AND INSTALLATION INSTRUCTIONS

3	General information	5
	About engineering and application practices	5
	Shipping	5
	Inspection before rigging	5
	Unit weights	7
	Anchoring	7
	Leveling	7
	Electrical connections	7
	Connecting pipework	8
	Coil connections	8
	Purge requirements	9
	Freeze protection	9
	Bleed Line Installation	9
	Safety Precautions	9
	Non-walking surfaces	11
	Modifications by others	11
	Warranty	11
4	Rigging	12
	General Notes	12
5	Section Assembly	16
	External motor support installation	19
	External motor installation	20
6	Optional Accessories Assembly	22
	General	22
	Discharge attenuator	22
	Clean out port	24
	Optional bottom connection	25
7	Inspection prior to start-up	26
	General	26
8	Further Assistance & Information	27
	The service expert for BAC equipment	27
	More information	27

About engineering and application practices

This bulletin only refers to the assembly of the unit. To ensure a proper operation, a correct integration of the unit in the overall installation is mandatory. For good engineering and application practices on layout, levelling, connecting pipework, etc., please refer to our website:
<http://www.baltimoreaircoil.eu/knowledge-center/application-information>.

Shipping

BAC cooling equipment is factory assembled to assure uniform quality and minimum field assembly. All units ship in three sections as standard.

If discharge sound attenuation and/or finned discharge coil(s) are included in the order, the section(s) ship separately for rigging on site.

For the dimensions and weights of a specific unit or section, refer to the certified drawing.



CAUTION

Do not cover units with PVC eliminators or fill with a plastic tarpaulin. Temperature increase due to sun radiation could deform the fill or eliminators.

Inspection before rigging

When the unit is delivered to the job site, it should be checked thoroughly to ensure all required items have been received and are free of any shipping damage prior to signing the bill of lading.

The following parts should be inspected:

- Sheaves and belts
- Bearings
- Bearing supports
- Fan motor(s)
- Fan guards
- Fan(s) and fan shaft(s)
- Wet deck surface
- Coils
- Water distribution system
- Strainers
- Float valve assembly
- Spray pump(s)
- Eliminators



- Combined inlet shields
- Interior / exterior surfaces
- Miscellaneous items

An envelope with check-list is stored in a wooden no nail crate or a plastic container which is placed in the lower section. For safety reasons, access doors / panels may be sealed with bolts. The following table specifies which wrench is required to open them.

Wrench to open access door
17 mm

Required wrenches to open access door

The wooden no nail crate / plastic container also contains miscellaneous parts such as gasket, hardware and accessory items.

At temperatures below -10°C the butyl sealer tape might lose its flexibility. We recommend to store the sealer tape in a heated room before using it during rigging at freezing temperatures.



CAUTION

Be sure to remove all miscellaneous items from the pan before the unit is assembled.

If the hardware is packed in a plastic container it is located in the cold water module (lower section) and fixed to a lifting ear.



Hardware location

If the hardware is packed in a wooden box, it is fixed with cord straps to the pump base.

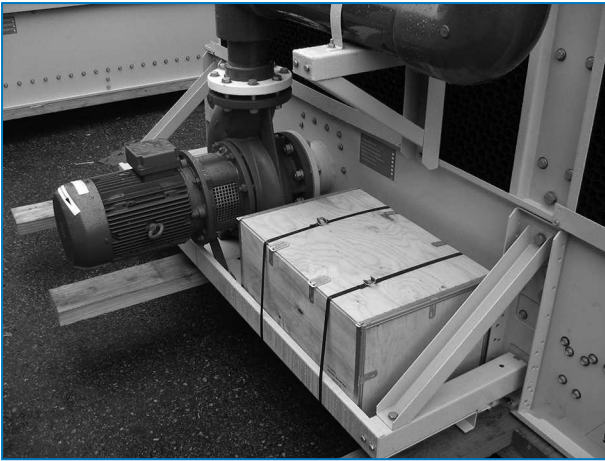

Hardware location

Unit weights

Before rigging any BAC equipment, the weight of each section should be verified on the unit certified drawing.

 These weights are **approximate** and should be confirmed by weighing **before lifting** when available hoisting capacity provides little margin for safety.



CAUTION

Before an actual lift is undertaken, ensure no water, snow, ice or debris has collected in the sump or elsewhere in or on the unit. Such accumulations will add substantially to the equipment's lifting weight.

In the event of extended lifts or where hazards exist, the lifting devices should be used in conjunction with safety slings placed under the unit.

Anchoring

The unit must be properly anchored in place.

Refer to the suggested support details on the certified drawing for locations of the mounting holes. Anchor bolts must be provided by others.

Holes suitable for 20 mm bolts are provided in the bottom flange of the lower section for bolting the unit to the support beams.

Leveling

The unit must be level for proper operation and ease of piping.

The unit should be level to 0,5 mm/m over the unit length and width.

Electrical connections

The units are delivered with a number of electrical components that need to be connected after rigging. For all electrical components, please refer to the specific wiring diagrams in the submittal package.

Connecting pipework

All piping external to BAC cooling equipment must be supported separately.

In case the equipment is installed on vibration rails or springs, the piping must contain compensators to eliminate vibrations carried through the external pipework.

Suction pipe sizing should be done according to good practice, which may for larger flows require larger pipe diameters than the outlet connection. In such cases adapter pieces need to be installed.

Coil connections

Hot dip galvanized and stainless steel coils of BAC closed circuit cooling towers are filled with a low pressure inert gas at the factory before shipping, to ensure an optimal internal corrosion protection. It is recommended to check the overpressure every six months (connect a manometer to the valve).

On site, the pressure needs to be released from the coil. Remove the plug first before opening the pressure relieve valve.

In case of threaded connections, clean up the thread prior to connecting it to the pipework.

Non-threaded connections must be bevelled on site before they can be welded.

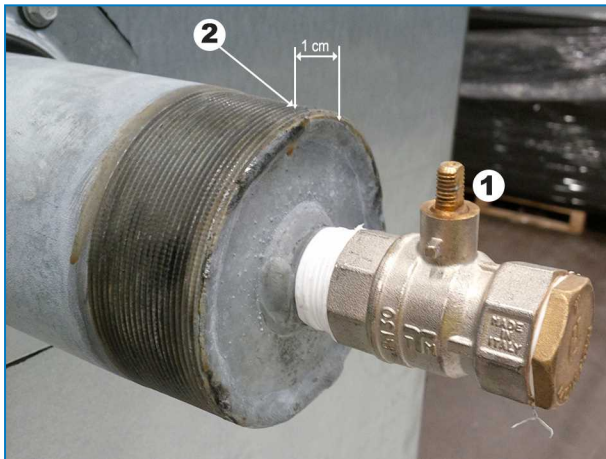

Upper coil connection with pressure release valve (on closed circuit towers with connections up to ND100).

1. Closed pressure release valve of upper coil connection.
2. After releasing the low pressure inert gas, cut coil connection here.



Lower closed-off coil connection (on closed circuit cooling towers with connections up to ND100).



CAUTION

Once the coil is no longer protected by the inert gas, proper actions against corrosion must be taken on site.

Purge requirements

The installer of BAC closed circuit cooling towers must ensure a proper air purging of the system prior to operation.

Entrained air can restrict the capacity of the cooler, resulting in higher process temperatures.

All connections (installed by others) must be leak free and tested accordingly.

Freeze protection

These products must be protected against damage and/or reduced effectiveness due to possible freeze-up by mechanical and operational methods. Please contact your local BAC representative for recommended protection alternatives.

Bleed Line Installation

On units operating with a remote sump tank, install a bleed line with valve between the system circulating pump discharge riser and a convenient drain. Locate the bleed line in a portion of the riser piping that drains when the pump is off.

Closed circuit cooling towers that are furnished with a factory installed circulating pump include a bleed line with valve.

The bleed valve should always be open when the unit is in operation, unless the bleed rate is automatically controlled by a water treatment system.

Safety Precautions

All electrical, mechanical and rotating machinery constitutes a potential hazard, particularly for those not familiar with its design, construction and operation. Accordingly, adequate safeguards (including use of protective enclosures where necessary) should be taken with this equipment both to safeguard the public (including minors) from injury and to prevent damage to the equipment, its associated system and the premises.

If there is doubt about safe and proper rigging, installation, operation or maintenance procedures, contact the equipment manufacturer or his representative for advice.

When working on operating equipment, be aware that some parts may have an elevated temperature. Any operations on elevated level have to be executed with extra care to prevent accidents.

AUTHORIZED PERSONNEL

The operation, maintenance and repair of this equipment should be undertaken only by personnel authorized and qualified to do so. All such personnel should be thoroughly familiar with the equipment, the associated systems and controls and the procedures set forth in this and other relevant manuals. Proper care, personal protective equipment, procedures and tools must be used in handling, lifting, installing, operating, maintaining and repairing this equipment to prevent personal injury and/or property damage. Personnel must use personal protective equipment where necessary (gloves, ear plugs, etc...)



MECHANICAL SAFETY

Mechanical safety of the equipment is in accordance with the requirements of the EU machinery directive. Depending upon site conditions it also may be necessary to install items such as bottom screens, ladders, safety cages, stairways, access platforms, handrails and toe boards for the safety and convenience of the authorized service and maintenance personnel.

At no time this equipment should be operated without all fan screens, access panels and access doors in place/closed and properly secured.

When the equipment is operated with a variable fan speed control device, steps must be taken to avoid operating at or near to the fan's «critical speed».

For more information consult your local BAC representative.

ELECTRICAL SAFETY

All electrical components associated with this equipment should be installed with a lockable disconnect switch located within sight of the equipment.

In the event of multiple components, these can be installed after a single disconnect switch but multiple switches or a combination thereof are also allowed.

No service work should be performed on or near electrical components unless adequate safety measures are taken. These include, but are not limited to the following:

- Isolate the component electrically
- Lock the isolation switch in order to prevent unintentional restart
- Measure that no electrical voltage is present any more
- If parts of the installation remain energized, make sure to properly demarcate these in order to avoid confusion

Fan motor terminals and connections may have residual voltage after unit shut-down. Wait five minutes after disconnecting the voltage at all poles before opening the fan motor terminal box.

LIFTING



CAUTION

Failure to use designated lifting points can result in a dropped load causing severe injury, death and/or property damage. Lifts must be performed by qualified riggers following BAC published Rigging Instructions and generally accepted lifting practices. The use of supplemental safety slings may also be required if the lift circumstances warrant its use, as determined by the rigging contractor.

LOCATION

All cooling equipment should be located as far away as possible from occupied areas, open windows or air intakes to buildings.



CAUTION

Each unit should be located and positioned to prevent the introduction of discharge air into the ventilation systems of the building on which the unit is located or those of adjacent buildings.



For detailed recommendations on BAC equipment layout, please see the BAC Application Handbook EU-Edition, the BAC website: www.baltimoreaircoil.eu or contact your local BAC Representative.



LOCAL REGULATIONS

Installation and operation of cooling equipment may be subject to local regulations, such as establishment of risk analysis. Ensure regulatory requirements are consistently met.

Non-walking surfaces

Access to and maintenance of any component needs to be performed in accordance with all local applicable laws and regulations. If the proper and required access means are not present, temporary structures need to be foreseen. Under no circumstance can one use parts of the unit, that are not designed as an access mean, unless measures can be taken to mitigate any risks that might occur from doing so.

Modifications by others

Whenever modifications or changes are made by others to the BAC equipment without written permission of BAC, the party who has done the modification becomes responsible for all consequences of this change and BAC declines all liability for the product.

Warranty

BAC will guarantee all products to be free from manufactured defects in materials and workmanship for a period of 24 months from the date of shipment. In the event of any such defect, BAC will repair or provide a replacement. For more details, please refer to the Limitation of Warranties applicable to and in effect at the time of the sale/purchase of these products. You can find these terms and conditions on the reverse side of your order acknowledgement form and your invoice.

General Notes



CAUTION

Before an actual lift is undertaken, ensure no water, snow, ice or debris has collected in the sump or elsewhere in the unit. Such accumulations will add substantially to the equipment's lifting weight.



CAUTION

When the unit is installed, all metal parts created by drilling, fastening self tapping screws, grinding, welding or other mechanical works must be removed from the unit. If they remain on the unit (typically on the double break flanges) this could lead to corrosion and eventually coating damage.

1. If the (pump) piping from coil products is split for transport reasons, the piping must be assembled on site by means of a flexible connection (typically a rubber sleeve or coupling).
2. Lifting devices have been provided on all sections. The tables below give the preferred method for rigging each section of a unit.

For additional information see further in this manual under: "Rigging" on page 1.

Refer to the following table for the minimum recommended vertical dimension "H" from the lifting device to the spreader bar. The use of a supplemental safety sling may also be required if the lift circumstances warrant its use, as determined by the rigging contractor.

Model number	Single piece lift		Three-piece lift					
	W (distance between lifting points) (mm)	H (min. height to spreader bar) (mm)	Lower section		Coil casing section		Mechanical section	
			W (distance between lifting points) (mm)	H (min. height to spreader bar) (mm)	W (distance between lifting points) (mm)	H (min. height to spreader bar) (mm)	W (distance between lifting points) (mm)	H (min. height to spreader bar) (mm)
PFI 0709E	2300	5200	2800	4300	2300	3400	2300	3000
PFI 0718E	2300	5200	5500	4300	2300	3400	2300	3000
PFI 0809E	2400	5200	2800	4300	2400	3400	2400	3700
PFI 0812E	2400	5200	3700	4300	2400	3400	2400	3700
PFI 0818E	2400	5200	5500	4300	2400	3400	2400	3700
PFI 1009E	3000	5800	2800	4300	3000	3400	3000	4300
PFI 1010E	3000	5800	3700	4300	3000	3400	3000	4300
PFI 1212E	3700	5800	3700	4300	3700	3400	3700	4900
PFI 1218E	3700	5800	5500	4300	3700	3400	3700	4900

Recommended vertical dimension and spreader bar length for PFI

The maximum permissible lift point width "W" should not exceed the listed value by more than 300 mm.

LIFTING

All standard PFI models are designed to be lifted in one assembled piece as shown in the following figure.

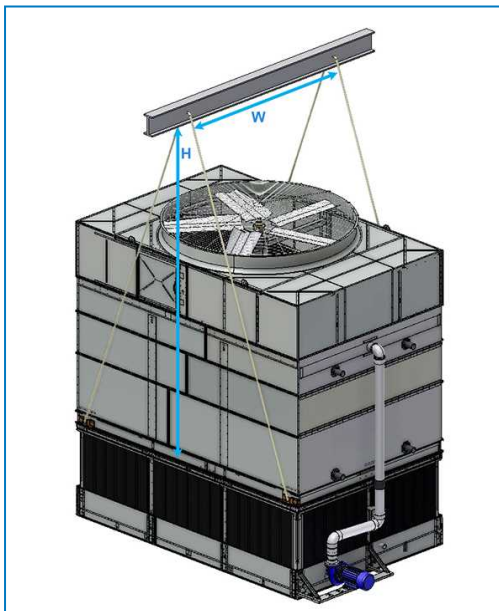

Single piece lift

A three-piece lift is also possible and is shown in the following figures.

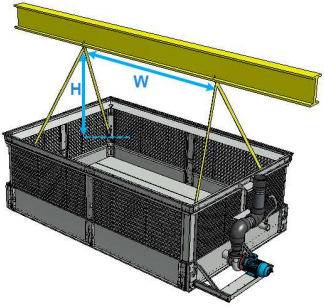
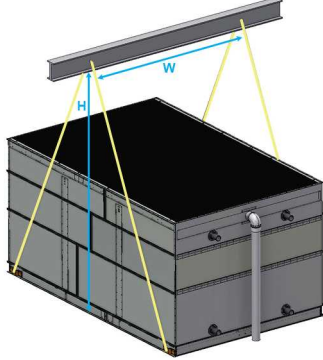
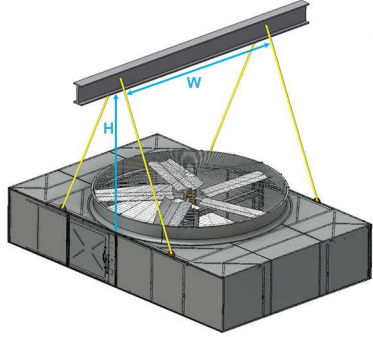
Water collection module	Heat transfer module	Air handling module
		
<p>Lower section Three-piece lift</p>	<p>Coil casing section Three-piece lift</p>	<p>Mechanical section Three-piece lift</p>

All sections require the use of a spreader bar. The distance between the spreader bar lifting points must be equivalent to the width between the unit lifting ears.



Pay attention to the difference in lifting ear and tie down buckle on the lower section.

The **lifting ear** is to be used to unload unit from truck. It is designed for **upward** force.

It is installed on the inside of the water collection module (corner bracket)

The **tie-down buckle** is only to be used to tie down (secure) unit onto truck for transport. It is designed for **downward** force only.

It is installed on the outside of the water collection module and only to be used to tie down (secure) unit onto truck for transport.



CAUTION

Do not use tie down buckle for lifting and lifting ears for tie down purpose.

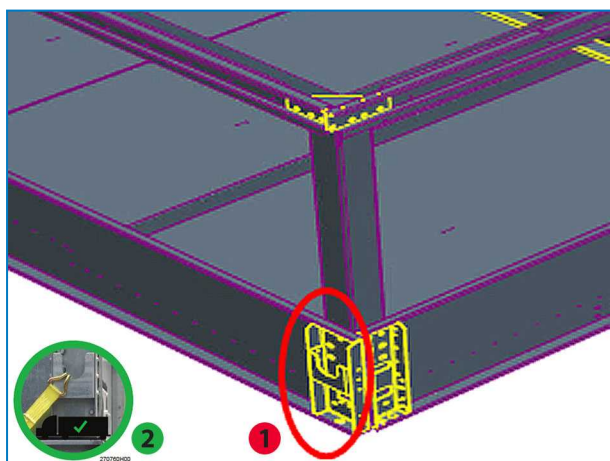

Position tie-down buckle on water collection module

1. Tie-down buckle
2. Proper use of tie down buckle

USE OF DRIFT PINS

The use of drift pins during section assembly is strongly recommended. Follow the below guidelines:

1. Use drift pins in the bolt holes provided. This will guide the section onto the next section.
2. Using at least four drift pins (see figure) in the fastening holes located on the long sides of the sections to align the upper section to the lower section. To avoid incorrect alignment, refer to the below drawing for the position of the fastening holes to be used. Use additional drift pins in the middle of the unit if required, to align long panels. Make sure all holes from upper section and lower section are properly aligned before lowering the upper section completely onto the lower section.

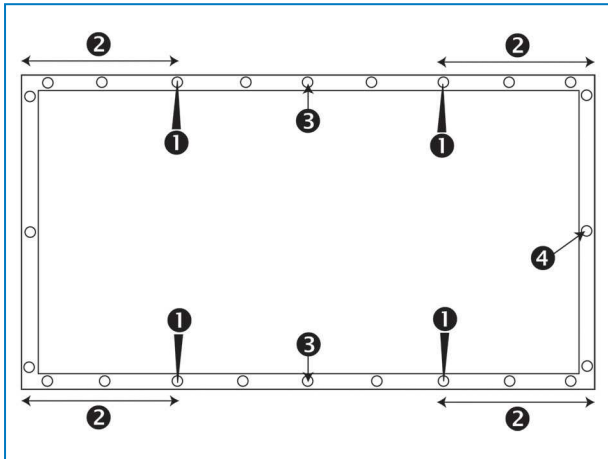

Position of the fastening holes to be used.

1. Drift pin position.
2. The distance between the fastening hole in which the drift pin is inserted and the corner should be at least 30 cm.
3. Usage of additional drift pin for long sides.
4. Fastening hole.

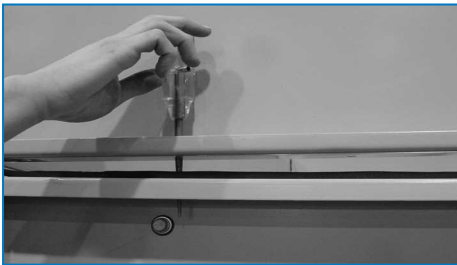

Usage of drift pin to align the screw holes



CAUTION

When lowering a section, ensure nothing can be trapped between the upper and lower flanges.

5

PFI SECTION ASSEMBLY



For 2.2 m and 2.4 m wide units the motor base assembly is shipped loose for field installation and must be removed from the lower section where it is stored for safe transport.

Remove any motors or accessories shipped in the lower section.

1. If not pre-installed, install rigging alignment pins on the lower section in the locations shown in the figure below. Secure the alignment pins using the M12 hardware provided.

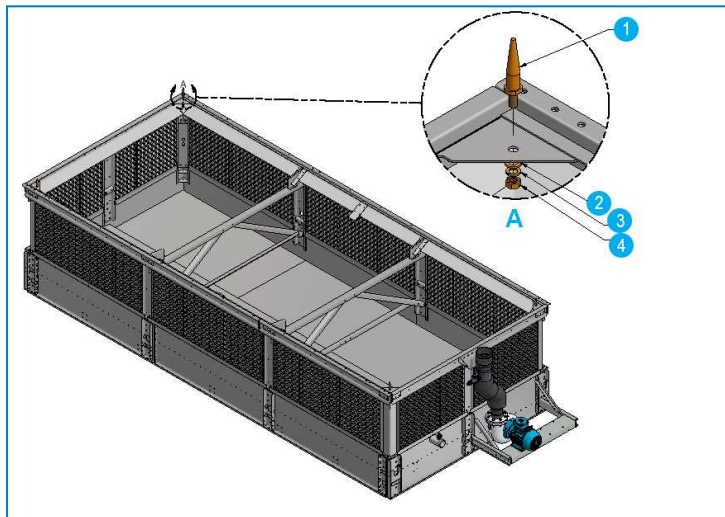

Installing rigging alignment pins

1. Alignment pin
 2. Flat washer M12
 3. Lock washer M12
 4. Nut M12
2. Position the lower section on the unit support and bolt into place. (Only applicable in case of 3-piece lift).
 3. Lower the hose connection on the pump discharge piping below the elevation of the lower section before rigging the coil casing section.
 4. Wipe any moisture or dirt from the perimeter of the top flange on the lower section and also from the perimeter of the top flange of the coil casing section.
 5. Starting at one end, install flat butyl sealer tape supplied with the unit, around the face of the flanges of the lower section in a continuous line. At each corner, allow 25 mm overlap.
 6. Lower the coil casing section until it is hovering 50 – 150 mm above the lower section.
 7. Insert drift pin as per figure below. Start at the corner hole and skip every 3 or 4 holes along the length of the unit. Repeat this process on the other side.



Corner alignment with drift pin

- Lower the coil casing section the remaining distance using the alignment pins and drift pins to align the coil casing section and lower section holes.



CAUTION

When lowering a section, ensure nothing can be trapped between the upper and lower flanges.

- Fasten the hardware between the coil casing section and the lower section as per figure below.

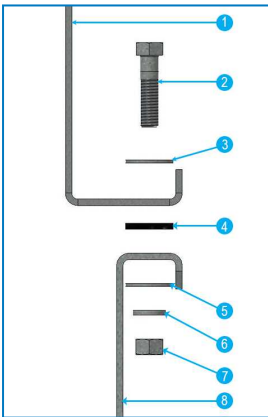

Coil casing / lower section bolt assembly

- Upper section
- Bolt M10
- Flat washer
- Flat butyl sealer tape
- Flat washer
- Lock washer
- Nut
- Lower section

- Ensure that moisture and dirt has been wiped from the perimeter of the top flange on the coil casing section, which is now connected to the lower section.

11. On the coil casing section, install a layer of foam tape supplied with the unit around the face of the flange over the centreline of the holes. Do not leave any gaps.
12. Lower the mechanical section until it is hovering 50 – 150 mm above the coil casing section.
13. Insert drift pin as per figure above. Start at the corner hole and skip every 3 or 4 holes along the length of the unit, inserting drift pins to align the mechanical section and coil casing section holes. Repeat this process on the other side and lower the mechanical section further.
14. As illustrated in the figure below secure the mechanical section to the coil casing section using the self-tapping screws provided. Start next to lifting ear towards centre of unit. Continue to install the screws using the drift pins to align the screw holes until all holes are filled with screws.

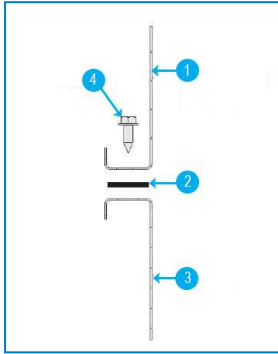

Mechanical / Coil casing section self tapper assembly

1. Mechanical section
2. Foam seal tape
3. Coil casing
4. 5/16" Self tapping screw

15. Lift the motor base assembly into position, next to the access door of the mechanical section and fasten (only for 2.2m and 2.4m wide units). For detailed information see further in this manual under: "External motor support installation" below. Another possibility is to install the motor base assembly on the mechanical section PRIOR to lifting and then lift this assembly in one piece (mechanical section + motor). However, while installing the motor base, the mechanical section cannot rest on the ground. Belts can be installed and tensioned at this moment as well.
16. If included in the order lift the discharge attenuator in place. For detailed information see further in this manual under "Discharge attenuator".
17. Position the hose connecting the sections of the pump discharge pipe and secure with the hose clamps provided.
18. Lift the unit, position it on the unit support and bolt into place (only applicable in case of single piece lift).

External motor support installation

1. Locate the mechanical support bolts on the access door side of the mechanical section.
2. Remove bolts but **under no circumstances remove tappers**. Removal of tappers will cause mechanical system to fall.
3. Align davit support with the holes in the mechanical system: the big holes in the support fall over the heads of the tappers which are not to be removed.

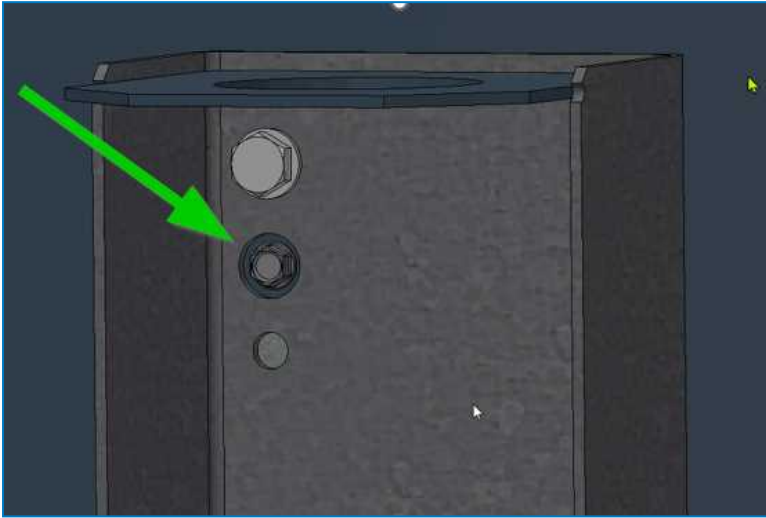

4. Reinstall bolts.

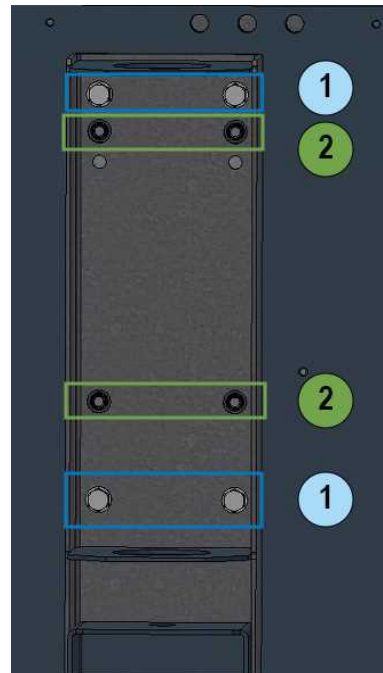
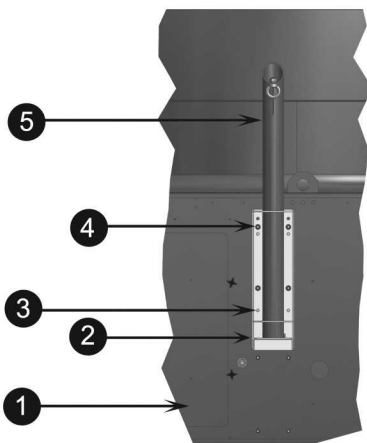

1: Bolts, 2: Tappers

Installation of motor removal davit support

1. Access door
2. Motor davit support (shipped loose)
3. Bolt, nuts & washers. (Use these to install motor davit support)
4. Tappers (4 pieces) do not remove (the support has big holes which go over the taper heads.).
5. Motor davit (shipped loose)



External motor installation

2,2 M AND 2,4 M WIDE UNITS

1. Attach lifting strap to the motor base eyelet and remove the motor and motor base assembly from the cold water basin shipping location. The motor assembly remains vertical to maintain proper alignment during installation.
2. Lift motor assembly into position next to the access door of the air handling module.
3. Attach the assembly to the unit using the six supplied studs and hardware.

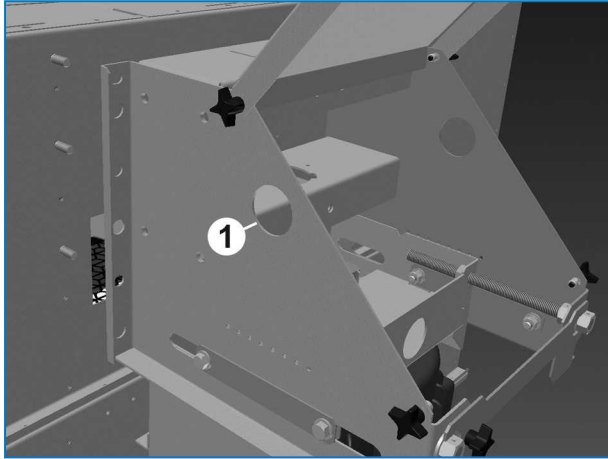

External motor mounting – Step 1

1. Motorbase eyelet

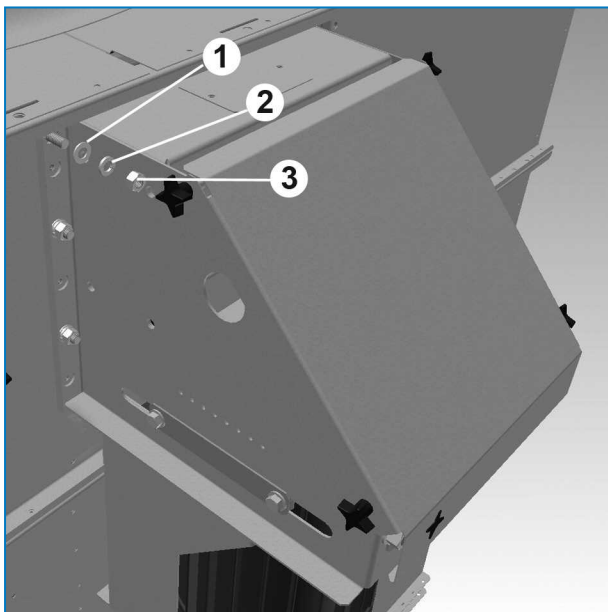

External motor mounting – Step 2

1. 12 mm washer
2. 12 mm lock washer
3. 12 mm nut

4. Install belts and check sheave alignment. Finally, tension the belts. For correct tensioning specifications and procedures, refer to the Operating and Maintenance Manual.



All other PFI models have fan motor mounted and tensioned at the factory.



PFI OPTIONAL ACCESSORIES ASSEMBLY

General

1. All required installation instructions for optional accessories are stored in the wooden no nail crate / plastic container which is placed in the lower section. See "Inspection Before Rigging" on page 1 - picture "Hardware Location".
2. The platform, ladder and railing is packed on a separate skid. The assembly hardware is packed in a plastic container and strapped to the platform, ladder or railing itself.

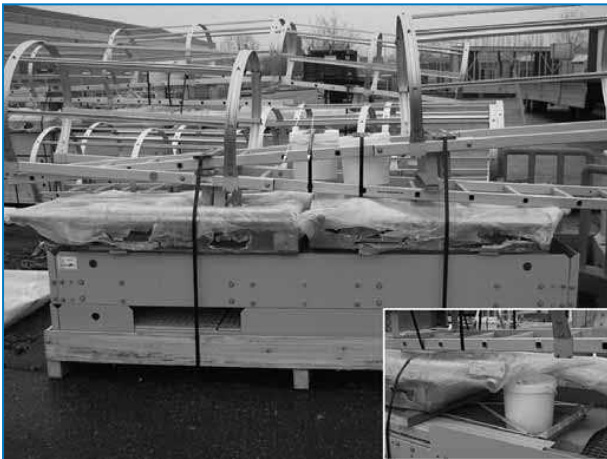

Hardware location for platform, ladder & railing

Discharge attenuator

1. Lift the discharge attenuator and be sure to follow the minimum height restrictions "H" found in the following table.

Model number	"H" (Distance from lift point to lifting device) (mm)
PFI 0709E, PFI 0718E, PFI 0809E PFI 0812E, PFI 0818E	2000
PFI 1009E, PFI 1012E	2500
PFI 1212E, PFI 1218E	3000

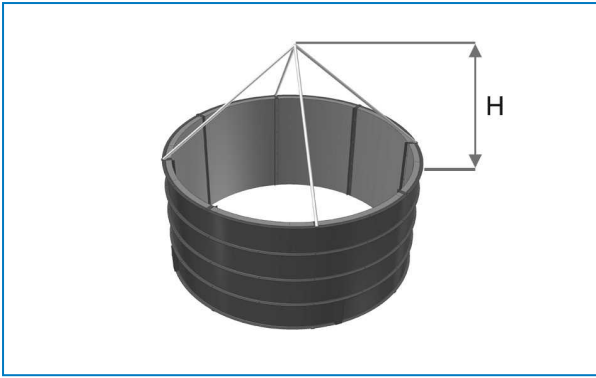

Lifting discharge attenuator

2. Position discharge attenuator on fan cowl of mechanical section by aligning the fan deck holes with the slotted discharge attenuator bracket holes.
3. Fasten discharge attenuator brackets to fan deck of mechanical section with self-tapping screws.

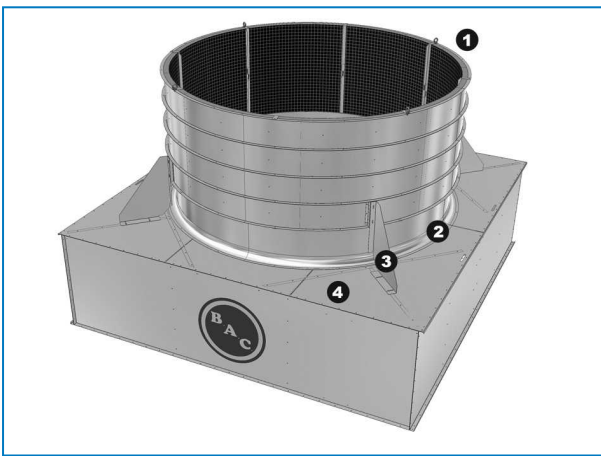

Discharge attenuator

1. Discharge attenuator
2. Fan cowl mechanical section
3. Discharge attenuator bracket
4. Fan deck mechanical section

Clean out port

Due to transport width limits, the cover flanges of the clean out port are mounted with flanges towards the inside (1). On site, the cover can be placed with flanges to the outside for easy access to hardware (2).

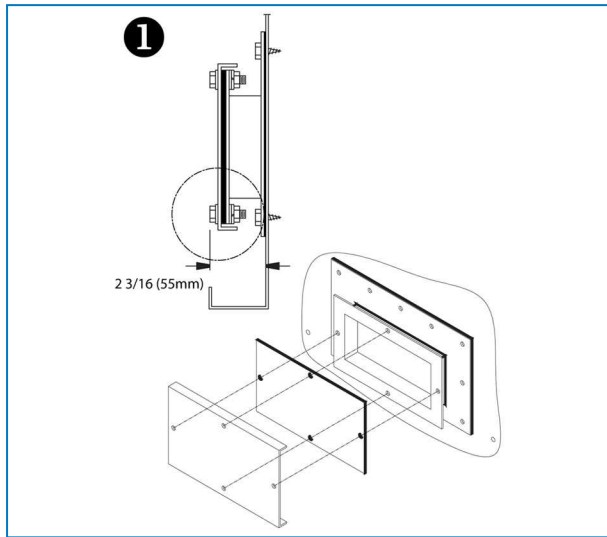

Clean out port cover mounted for transport

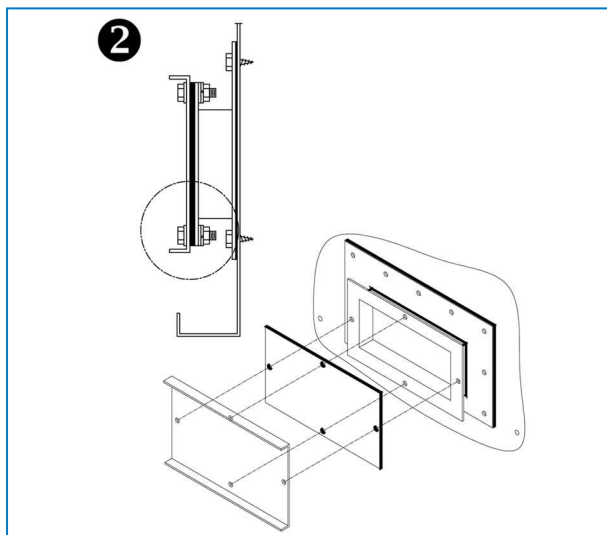

Final installation of clean out port cover

Optional bottom connection



To install the optional bottom connection, follow the instructions according to the following figure(s).

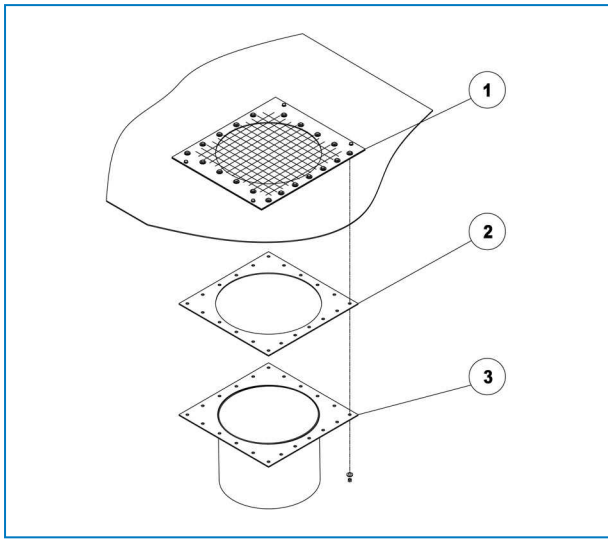

Installation of optional remote sump connection in bottom

1. Back-up plate with screen
2. Rubber gasket
3. Remote sump connection



PFI INSPECTION PRIOR TO START-UP

General

Prior to start-up, the following services, which are described in detail in the Operating and Maintenance Manual (see table "Recommended maintenance and monitoring programme") must be performed.

Proper start-up procedures and scheduled periodic maintenance will prolong the life of the equipment and ensure trouble-free performance for which the unit is designed.



The service expert for BAC equipment

We offer tailored services and solution for BAC cooling towers and equipment.

- Original spare parts and fill -for an efficient, safe and year round reliable operation.
- Service solutions - preventive maintenance, repairs, refurbishments, cleaning and disinfection for reliable trouble-free operation.
- Upgrades and new technologies - save up energy and improve maintenance by upgrading your system.
- Water treatment solutions - equipment for controlling corrosion scaling and proliferation of bacteria.

For more details, contact your local BAC representative for further information and specific assistance at www.BACservice.eu

More information

REFERENCE LITERATURE

- Eurovent 9-5 (6) Recommended Code of Practice to keep your Cooling System efficient and safe. Eurovent/Cecomaf, 2002, 30p.
- Guide des Bonnes Pratiques, Legionella et Tours Aéroréfrigérantes. Ministères de l'Emploi et de la Solidarité, Ministère de l'Economie des Finances et de l'Industrie, Ministère de l'Environnement, Juin 2001, 54p.
- Voorkom Legionellose. Ministerie van de Vlaamse Gemeenschap. December 2002, 77p.
- Legionnaires' Disease. The Control of Legionella Bacteria in Water Systems. Health & Safety Commission. 2000, 62p.
- Hygienische Anforderungen an raumluftechnische Anlagen. VDI 6022.

INTERESTING WEBSITES

Baltimore Aircoil Company	www.BaltimoreAircoil.com
BAC Service website	www.BACservice.eu
Eurovent	www.eurovent-certification.com
European Working Group on Legionella Infections (EWGLI)	EWGLI
ASHRAE	www.ashrae.org
Uniclimate	www.uniclimate.fr
Association des Ingénieurs et techniciens en Climatique, Ventilation et Froid	www.aicvf.org
Health and Safety Executive	www.hse.gov.uk

ORIGINAL DOCUMENTATION



This manual is originally made in English. Translations are provided for your convenience. In the event of discrepancies, the English original text shall prevail over the translation.



A series of horizontal dotted lines for writing, spanning the width of the page.



A series of horizontal dotted lines for writing, spanning the width of the page.



A series of horizontal dotted lines spanning the width of the page, providing a template for writing or data entry.





A series of horizontal dotted lines for writing, spanning the width of the page.



A series of horizontal dotted lines spanning the width of the page, providing a template for writing or data entry.





A series of horizontal dotted lines for writing, spanning the width of the page.

COOLING TOWERS

CLOSED CIRCUIT COOLING TOWERS

ICE THERMAL STORAGE

EVAPORATIVE CONDENSERS

HYBRID PRODUCTS

PARTS, EQUIPMENTS & SERVICES

BLUE by nature
GREEN at heart



www.BaltimoreAircoil.com

Europe@BaltimoreAircoil.com

Please refer to our website for local contact details.

Industriepark - Zone A, B-2220 Heist-op-den-Berg, Belgium

© Baltimore Aircoil International nv